



## Level Approach or Ramped Approach?

- In an ideal world, access to all buildings would be level, enabling everyone to enter with ease.
- In the real world, though, this is not realistic, as changes of level exist everywhere.
- Site conditions often mean we need to rely on the use of external ramps and steps to reach a building entrance.
- Where steps and ramps are necessary, designing them carefully from the beginning can eliminate the need for unsatisfactory retrospective changes.
- Where level access is not achievable, ramps enable wheelchair users and people with pushchairs or wheeled luggage to overcome changes in level.
- Not all people can use a ramp therefore in addition to a ramp, suitably designed steps should also be provided where the rise of the ramp is more than 300mm.
- **We suggest level approach where space is available as the best option for all, and this can also reduce installation costs significantly.**

### Definition: Is it a Level Approach or a Ramped Approach?

**Level approach:** is the ideal solution in all cases, a gradient no steeper than 1:60 along its whole length. Alternatively a gradient between 1:20 and 1:60 is still a level approach but resting areas are required, these need to be level platforms and the slope must not rise more than 500mm between level landing areas (rest area) over a length of 10m minimum (less distance than this would create a ramp)

**IMPORTANT NOTE:** This is the ideal solution and by providing this design, it generally removes the need for colour contrast in the paving and also handrails.

**Ramped approach:** Where the approach is steeper than 1:20, this is classed a ramped approach and must be designed as such.

### Useful Information

How to find the gradient of a ramp?

- Divide the length of the ramp (or available space) by the height that it rises (step height). This will give you the ramp gradient of **X**, expressed as 1 in X or 1: X

**Examples:**

- A ramp measuring 10m long that rises by 0.5 m =  $10/0.5=20$  therefore 1 in 20 (for every one metre the ramp rises it is 20 metres long).
- A space of 3m (3000mm) is available and the step is 200mm then

$3000\text{mm}/200\text{mm} = 15$  or 1:15, this would give a ramp shallower than the requirement therefore better

**Ramps with Design In Accordance with the Building Regulations**

Maximum gradient	Maximum rise	Max Length of ramp
1 in 12	166mm	2m
1 in 13	230mm	3m
1 in 14	285mm	4m
1 in 15	333mm	5m
1 in 16	375mm	6m
1 in 17	411mm	7m
1 in 18	444mm	8m
1 in 19	473mm	9m
1 in 20	500mm	10m

**Note:** No ramp can be longer than 10m and rise more than 500mm without a level landing (rest area)

Relationship graph between ramp gradient and the length of the ramp (going)

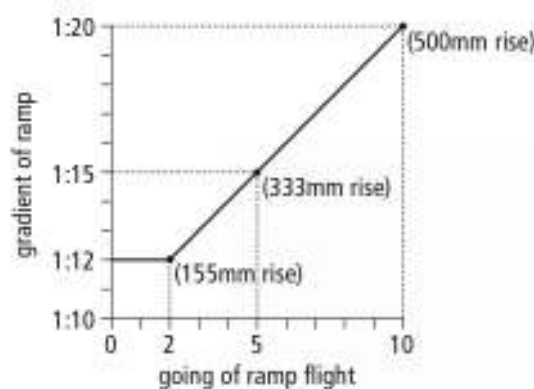

## Approach to the Building © Centre for Accessible Environments

Consideration to passing places is required in the design from the boundary to the entrance of the building. This drawing details some of the more common considerations. Surface materials need to be suitable for wheelchairs or similar.

See Approved document M for full guide, there is a link on the final page.

*Figure 4*  
**Path dimensions**

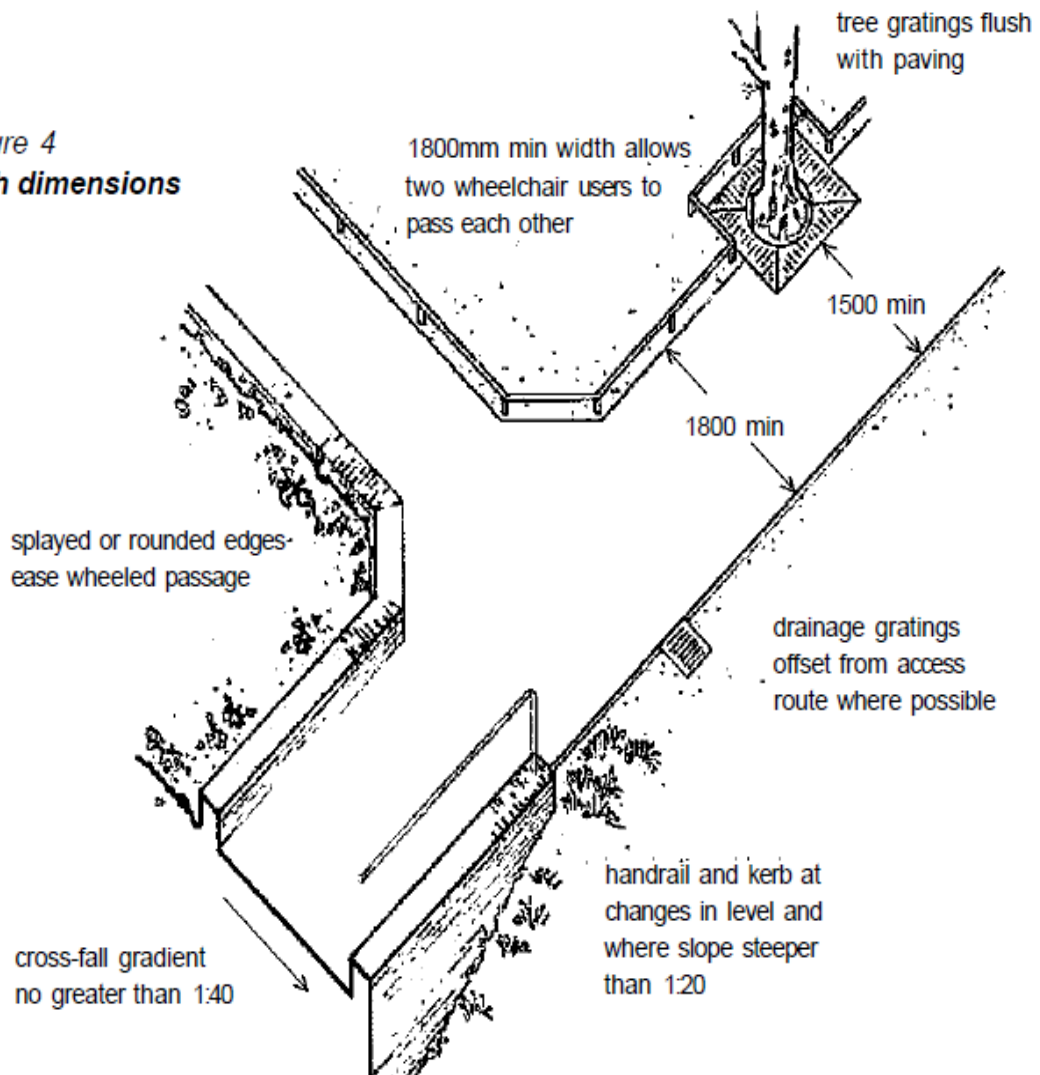

## Short-rise ramp design © Centre for Accessible Environments

Ramps should be provided as an alternative, not as a replacement, for steps. They should be suitable for independent access by wheelchair users – gradients, dimensions, colour contrast, handrails etc should all meet the requirements of Part M. There should be a clear, level space at the top of a ramp, away from the range of outward opening doors.

Although with a rise less than 300mm, steps are not required, we would always encourage these as good practice. See the following drawing for guidance

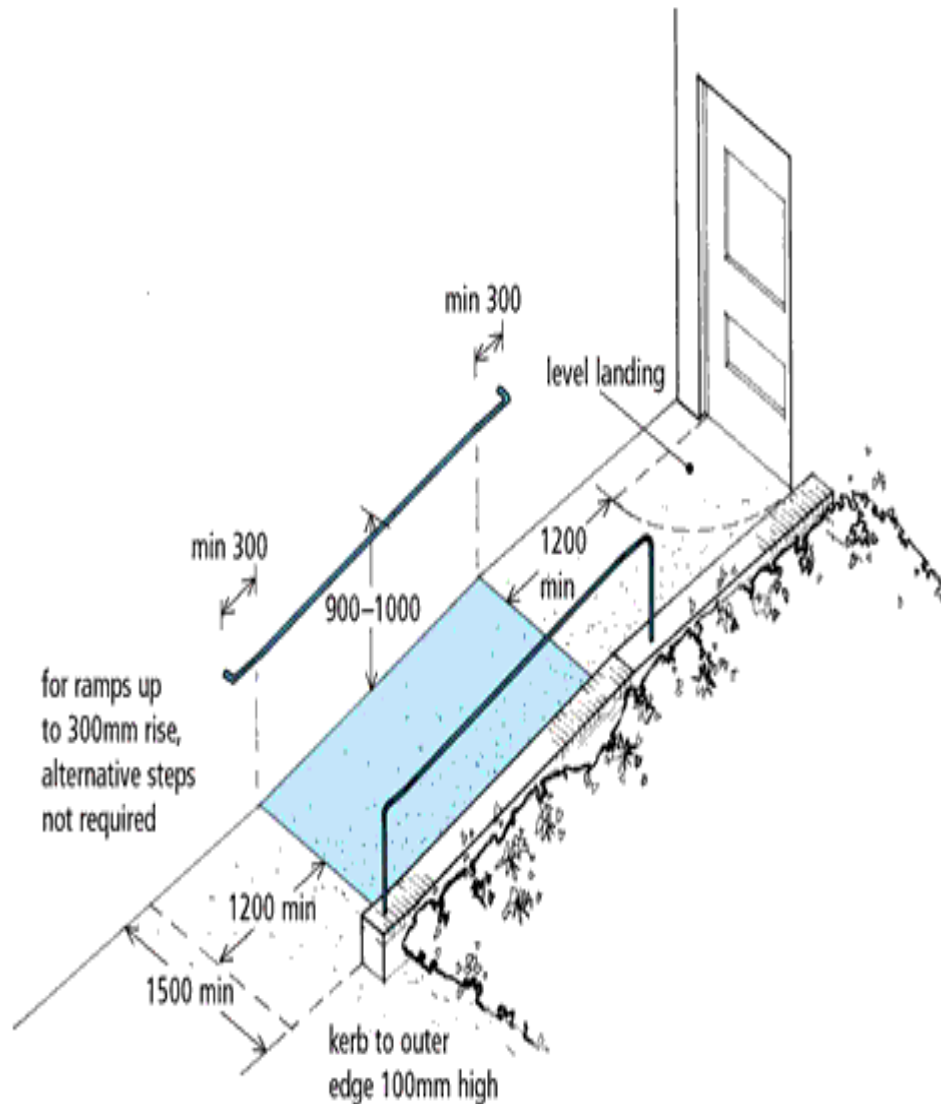

### Ramp with adjacent steps © Centre for Accessible Environments

Ramps should be accompanied by steps where the rise of the ramp is greater than 300mm. If the total rise exceeds 2m, an alternative means of access (such as a lift) should be used.

The following diagram shows recommended dimensions for a ramp with adjacent steps.

A tactile corduroy warning surface should also be incorporated at the **top and bottom** of an external flight of stairs.

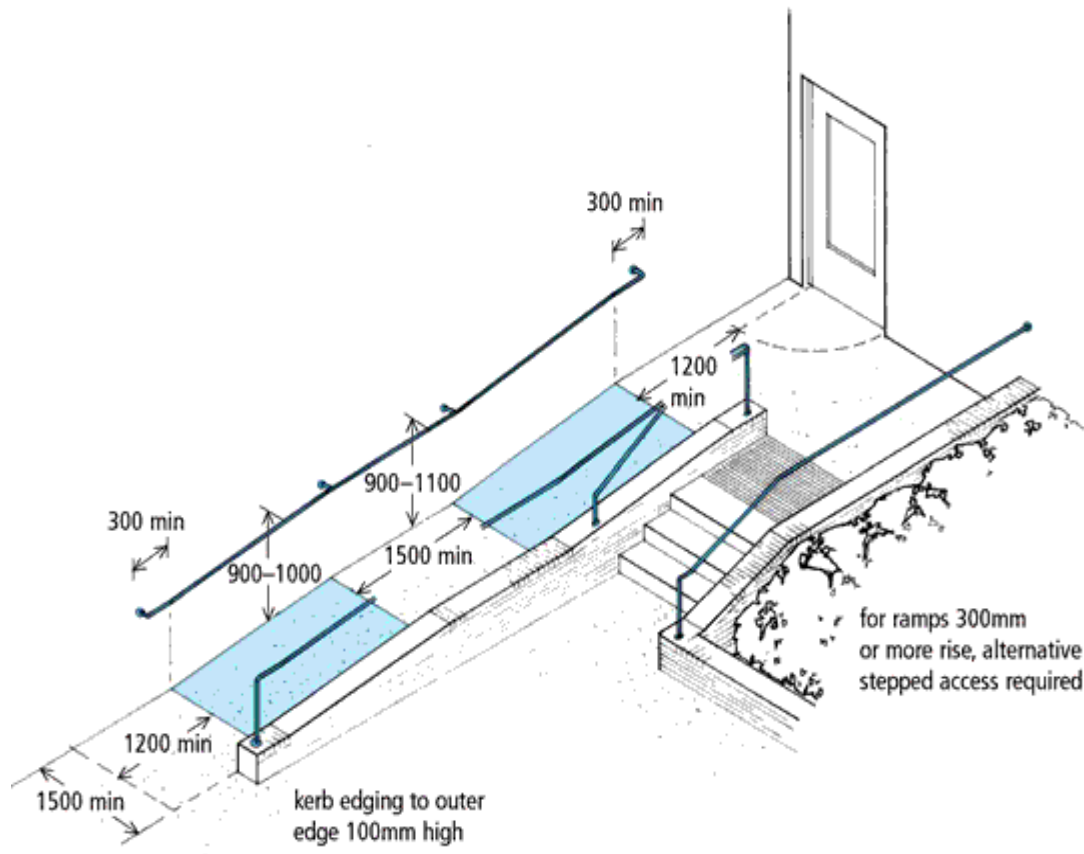

### External Steps © Centre for Accessible Environments

Highlighted nosing should be provided each step's tread and riser, to help visually impaired people identify the location of the steps, these should be **55mm wide on both the tread and riser**

Handrails should be installed alongside both sides of a flight of steps, to aid those with mobility impairment. Details on page 8

A tactile corduroy warning surface should also be incorporated at the **top and bottom** of an external flight of stairs. The key dimensions and design detail can be found in the following diagram but full reference to Approved Document M or BS8300 should be made.

Handrails should be:

- continuous across flights and landings
- easy to grip, and should provide good forearm support for those unable to grip, coated where necessary to ensure they are not cold to the touch, be easily distinguishable from the background through the use of good visual contrast, material such as hardwood are not cold to the touch.

Handrails need to extend a minimum 300mm beyond the top and bottom step and have closed ends.

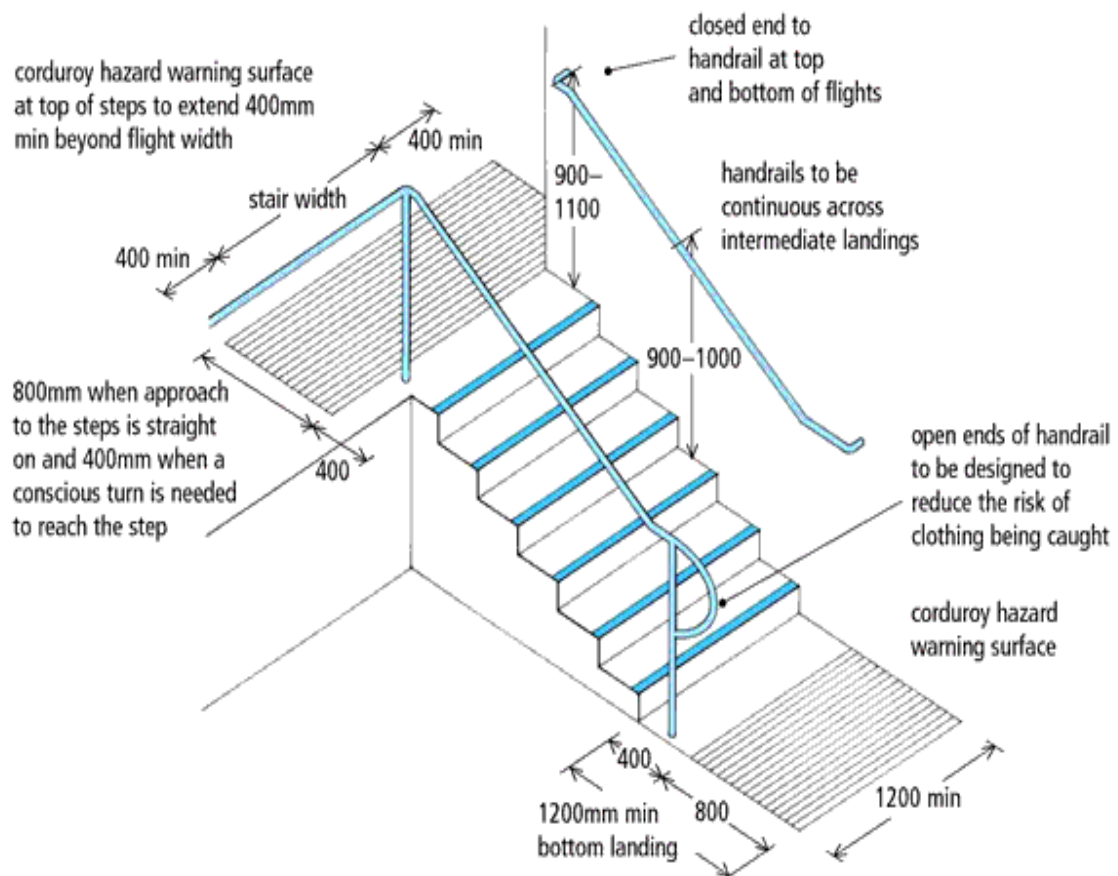

## Acceptable Handrail profiles

### Handrail profiles

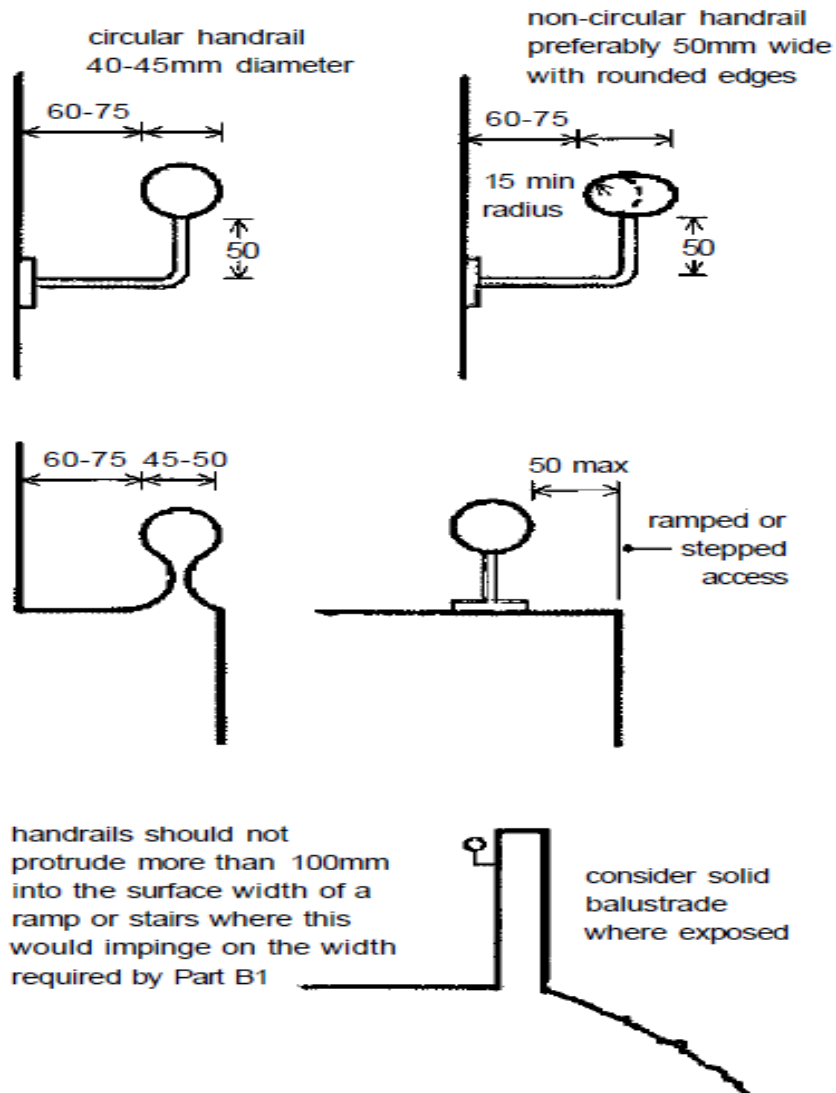

Further guidance on this and other subjects are at:

[http://www.charnwood.gov.uk/pages/building\\_control\\_guidance\\_sheets](http://www.charnwood.gov.uk/pages/building_control_guidance_sheets)

Link to the Approved Document is at:

[http://www.charnwood.gov.uk/pages/useful\\_links](http://www.charnwood.gov.uk/pages/useful_links)

**If in doubt ask!**