



BS5837:2012 Tree Survey
 Land west of Leconfield Road
 Loughborough
 Leicestershire
 NGR SK50951 17549

Survey by
 Christopher Barker CEnv dipHort ACIEEM

 www.smasltd.com <small>as recognised by</small>  SAFETY SCHEMES IN PROCUREMENT	Report prepared by: C Barker	Date Issued: 23 November 2020
		Report Version: Final
	Reviewed by: KLB	
	Report ref: P2164 /1020 /02	C B E Consulting Highbank, 5 Grantham Road, Navenby Lincoln. LN5 0JJ. Telephone (01522) 810086. www.cbeconsulting.co.uk

BS5837 Tree Survey, Land west of Leconfield Road

Contents

1. Introduction
 - 1.1 Site Description and Location
 - 1.2 Neighboring land uses
2. Tree Survey Appraisal Methodology
 - 2.1 Survey Objectives
 - 2.2 Survey Methodology
 - 2.3 Site plans and tree schedule
 - 2.4 Potential for Protected Species
3. Tree Survey Findings
 - 3.1 Survey Details
 - 3.2 Mature and Semi-Mature Trees
4. Tree Management
 - 4.1 Indicative Arboricultural Assessment
 - 4.2 Recommendations

Appendices

Appendix 1 - Tree Survey Table

Figures

- Figure 1 – Site Location Plan
- Figure 2 – Aerial Context Photograph
- Figure 3 – Tree Location Plan
- Figure 4 – Root Protection Area Plan
- Figure 5 – Constraints and Tree Protection Plan

The report and the site assessments carried out by CBE Consulting on behalf of the client in accordance with the agreed terms of contract and/or written agreement were performed with the skill and care ordinarily exercised by a reasonable Environmental Consultant at the time the Services were performed. Further, and in particular, the Services were performed by CBE Consulting taking into account the limits of the scope of works required by the client, the time scale involved and the resources agreed with the client.

Other than that expressly contained in the paragraph above, CBE Consulting provides no other representation or warranty whether express or implied, in relation to the services.

This report is produced exclusively for the purposes of the client. Unless expressly provided in writing, CBE Consulting does not authorise, consent or condone any party other than the client relying upon the services provided. Any reliance on the services or any part of the services by any party other than the client is made wholly at that party's own and sole risk.

This report is based on site conditions, regulatory or other legal provisions, technology or economic conditions at the time the survey was carried out. These conditions can change with time and reliance on the findings of the survey under changing conditions should be reviewed.

CBE Consulting accepts no responsibility for the accuracy of third-party data used in this report.

1 Introduction

1.1 Site Description and Location

The site is a roughly rectangular parcel of grassland situated on the western end of Leconfield Road, Loughborough, Leicestershire centred on grid reference SK50951 17549. The site is situated between residential development to the north, east and south and a block of deciduous woodland identified as Burleigh Wood to the west.

The location of the site is shown on the plan within **Figure 1** and an aerial photograph has been provided within **Figure 2** to place the site in context.

The site lies within the Borough of Charnwood and is not within a designated Conservation Area. Telephone consultation with Charnwood Borough Council has not identified any Tree Preservation Orders associated with this parcel of land but it should be taken into consideration that Burleigh Wood is a designated Local Wildlife Site.

In order to prepare a development plan for the site the Client has requested a BS5837 (2012) Tree Survey should be completed to assess the quality of the trees within and close to the boundary of the field and the impact any development may have on these. An inspection of the site was completed on 23rd October 2020. A photographic record of the trees at the site is included within the report.

Figure 1: Site location.

Image copyright Microsoft Corporation 2020

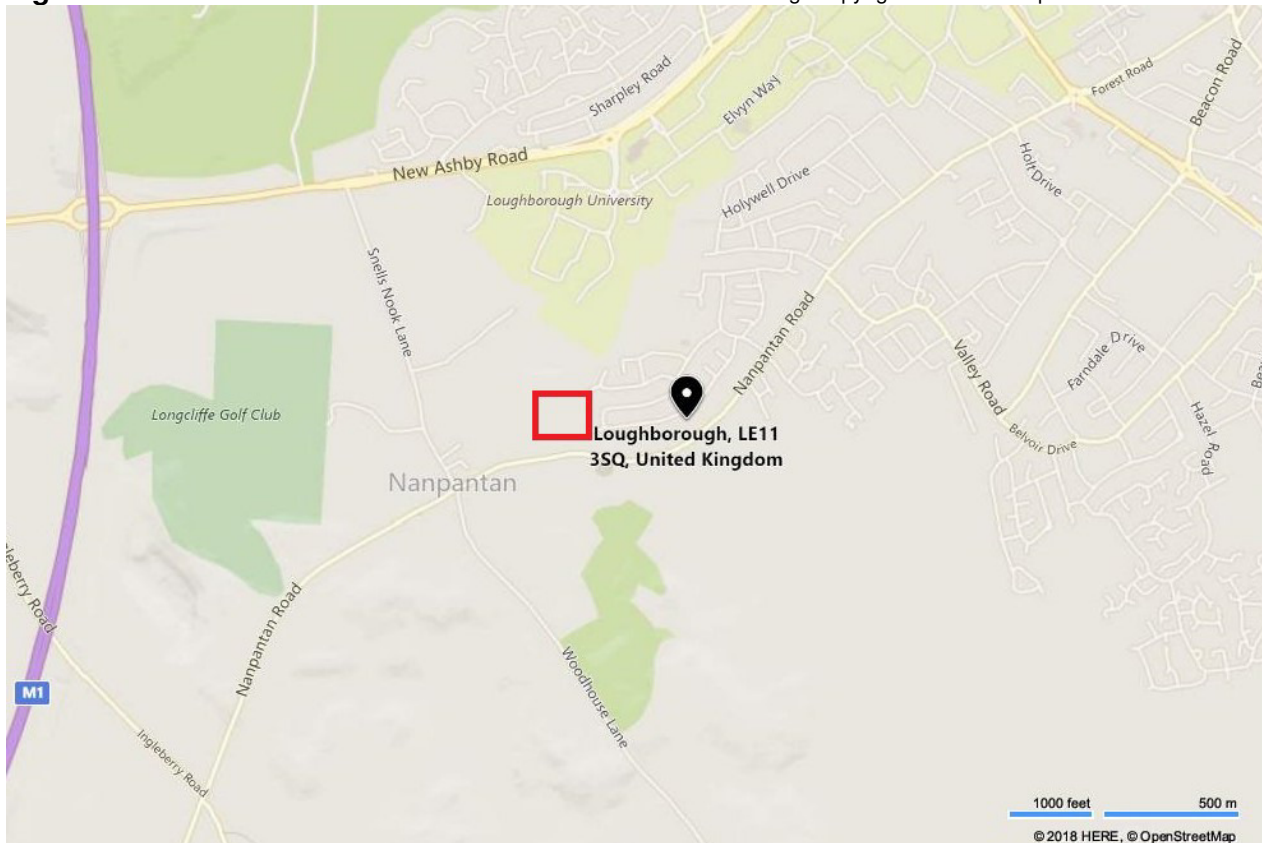

1.2 Neighbouring Land Uses

The survey area is a field of grassland situated on the margin of Loughborough and Nanpantan with housing to the north, east and south side and a large area of broadleaved woodland to the west. There are a number of specimen trees within the adjacent gardens close to the boundary of the field. An aerial photograph has been provided below to place the site in context.

Figure 2: Site Contextual Aerial Photograph

Image copyright Microsoft Corporation 2020



In undertaking the tree survey the assessment has been carried out in accordance with the specifications contained within BS 5837 Trees in Relation to Design, Development and Construction (2012). An inspection of the site and the immediate surrounding areas was completed by Christopher Barker, dipHort, CEnv, an experienced arboricultural consultant and licensed bat worker.

2. Tree Survey Appraisal Methodology

2.1 Survey Objectives

This tree survey has been carried out with the objective of:

- Identifying the individual tree species present at the site by means of visual inspection;
- To define the approximate age, condition and canopy spread of all individual mature and semi-mature trees identified and the value of these within the development context;
- To identify any trees that present a risk to existing or proposed foundations or other structures that may be constructed on the site and recommend action to remove this risk; and
- Recommend tree management / mitigation measures where appropriate.

The survey broadly assessed the condition and arboricultural value of the trees lying in or adjacent to the site area, paying attention to any mature individual trees present within or adjacent to the site area in order to prepare an assessment in accordance with BS 5837 Trees in Relation to Design, Development and Construction (2012).

2.2 Survey Methodology

The methodology set out below is a summary of the suggested approach to tree assessment as described in British Standard 5837:2012.

Trees have been broadly assessed based on guidance set out within the British Standard BS 5837:2012 'Trees in Relation to Design, Development and Construction'. This standard provides recommendations and guidance on the principles to be applied to achieve successful integration of development with trees, shrubs and hedgerows.

Trees on the site have been divided into one of four categories (based on the cascade chart for tree quality assessment). These are classed as A, B, C or U (Section 4 of BS 5837) within the table in Appendix 1. This gives an indication as to the tree's importance in relation to the site, the local landscape and, also, the value and quality of the existing trees on site.

Category (A): Trees whose retention is most desirable and are of high quality and value. These trees are considered to be in such a condition as to be able to make a lasting contribution (a minimum of 40 years).

Category (B): Trees whose retention is considered desirable and are of moderate quality and value. These trees are considered to be in such a condition as to make a significant contribution (a minimum of 20 years).

Category (C): Trees that could be retained and are considered to be of low quality and value. These trees are in an adequate condition to remain until new planting could be established (a minimum of ten years) or are young trees with a stem diameter below 150 mm.

Category (U): Trees that are considered to have no significant landscape value but it is not presumed that there is any overriding need to remove these unless stated otherwise in the description and recommendations. They are for this reason not considered as being significant within the planning process.

Species have been recorded by common and scientific name. Height has been estimated in metres and stem diameter measured in centimetres unless impractical, taken at a height of 1.5 m from the base of the tree.

The overall condition of any individual tree, or group of trees, has been referred to using one of the definitions listed below. A more detailed description of condition has been noted in the Tree Schedule.

G **Good:** A sound tree or trees needing little, if any, attention

- F **Fair:** A tree or trees with minor but rectifiable defects or in the early stages of stress, from which it may recover
- P **Poor:** A tree or trees with major structural and physiological defects or stressed such that it would be very expensive and inappropriate to retain
- D **Dead:** A tree or trees no longer alive. However, this could also apply to those trees that are dying and will be unlikely to recover, or are becoming or have become dangerous

The survey was completed from ground level only. Aerial inspections were not undertaken. Evaluations of tree conditions given within this assessment apply to the date of survey and cannot be assumed to remain unchanged, and it may be necessary to review these within 24 months, in accordance with good arboricultural practice.

2.3 Site Plans & Tree schedules

The position of significant individual trees or groups of trees on the site is shown on the Tree Location Plan **Figure 3**. Within the summary table (**Appendix 1**) a calculated corresponding radius of the circle for each RPA has been calculated. The Root Protection Areas are formulated to assist when designing layouts in relation to trees and the calculated RPA's in Appendix 1 should be used to inform the design layout of this site. A root Protection Area plan has been prepared as **Figure 4** and a Constraints Plan showing RPA's and protection areas has been prepared using the development plan as a base is provided as **Figure 5**.

2.4 Potential for Protected Species

Potential bat roost locations are described within this report using the methodology as that recommended by the Bat Conservation Trust (BCT). Each tree of significant size assessed within this survey has also been assessed for the potential to provide roosts for bats and the table in Appendix 1 includes reference to this. Table 1 below classifies the potential categories as accurately as possible. This table is based upon Table 8.4 in Bat Surveys- Good Practice Guidelines

Tree category	Survey / mitigation requirements	Trees within this category.
Category 1 Confirmed bat roost with field evidence such as live / dead bats, droppings, scratches, grease marks and / or urine staining.	Further assessment e.g. dusk / dawn surveys should be undertaken to provide information on the roost type, numbers and species of bat present. Avoid disturbance where possible. Felling or other works that would affect the roost would require an EPS licence with like for like roost replacement as a minimum. Works may also be subject to timing constraints.	None
Category 2a Trees that have a moderate / high potential to support bat roosts such as significant suitable cavities but no actual field evidence to confirm the presence of bats.	Further assessment e.g. dusk / dawn surveys should be undertaken to confirm the presence / absence of roosting bats. If no bats are found avoid disturbance if possible or resurvey immediately prior to felling. Use soft felling techniques and avoid direct disturbance of cavities during felling.	Oak T6 Group G7
Category 2b Trees with a low potential to support bat roosts showing only minor features such as shallow cavities, peeling bark etc. with no actual field evidence to confirm the presence of bats	Surveys only likely to be required immediately prior to felling as a precaution e.g. dusk or dawn survey. If such trees are to be felled reasonable avoidance measures should be taken such as soft felling and removal of ivy cover by hand.	Ash T4 Oak T3
Category 3 Trees with negligible potential to support bat roosts.	No further survey work of assessment likely.	

3. Tree Survey Findings

3.1 Survey Details

The tree inspection took the form of a walkover inspection completed by Christopher Barker dipHort, CEnv. Each individual semi-mature or mature tree of significance that could be impacted by any proposed new development within the survey area was identified, visually inspected and classified. The character of the trees at the site is shown in photographs contained within this section.

3.2 Mature and Semi-Mature Trees

A total of eight individual trees and three tree groups have been identified and assessed as part of the tree survey. The majority of the trees form a line along the western boundary of the site area but there are a number of individual mature and semi-mature trees within gardens along the other boundaries.

Trees T1 – T3 comprise two Birch trees of Category B and one Oak of Category A positioned within a garden approximately 1m to the south of the field boundary. These trees provided canopy cover and partial screening to the garden supported by a trimmed Hawthorn hedge. These are trees of good quality and the canopies extend across the field boundary at height. It is unlikely any facilitation pruning will be required but the RPA's will need to be protected.



T1 – T2



Oak T3

Trees T4 and T5 are situated in adjacent land close to the south western corner of the site. Ash T4 is a large mature tree of significant stature placed within Category B. The RPA and canopy of this tree extend across the field boundary and will require protection measures. Willow T5 is a small tree of little landscape significance that present no constrain to development and it is placed within Category C.



Ash T4

Trees T6 and Group G7 comprise mature Oak along the boundary of Burleigh Wood. These are trees of significant stature with many other mature trees further to the west forming a large woodland area. These trees are highly visible from within the site and adjacent residential houses and are placed within Category A. The crown extents and RPA extend across the site boundary and protection measures will be required.



Group G8 comprise a linear group of closely planted Leylandii trimmed along the sides to form a vertical screen along the southern boundary of a residential garden. These trees are placed within Category B. They are not of large stature but do provide excellent screening to the adjacent garden.



Trees T9 – T11 are small Holly and Leylandii positioned within adjacent gardens close to the boundary of the field. None are specimens of significant stature but all are visible from within the field interior and provide some screening to the adjacent gardens supported by trimmed hedgerows. Leylandii T10 is placed within Category B and Holly T9 and T11 are placed within Category C. The RPA's of these trees extend across the site boundary and will require protection measures.



Key
 Blue – Category A
 Green – Category B
 Yellow – Category C

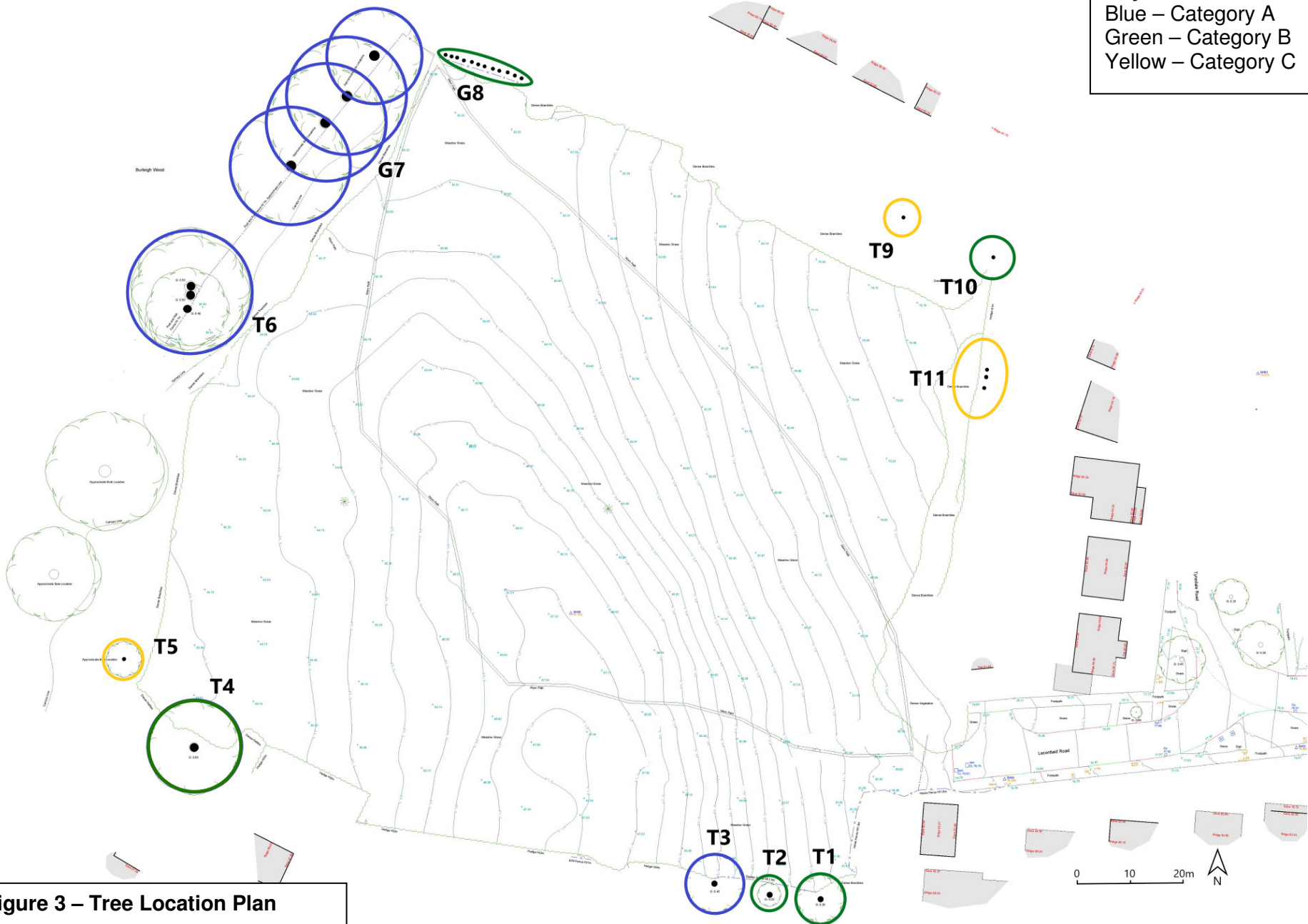

Figure 3 – Tree Location Plan

Key
RPA shown as red circle
with radius stated in meters.

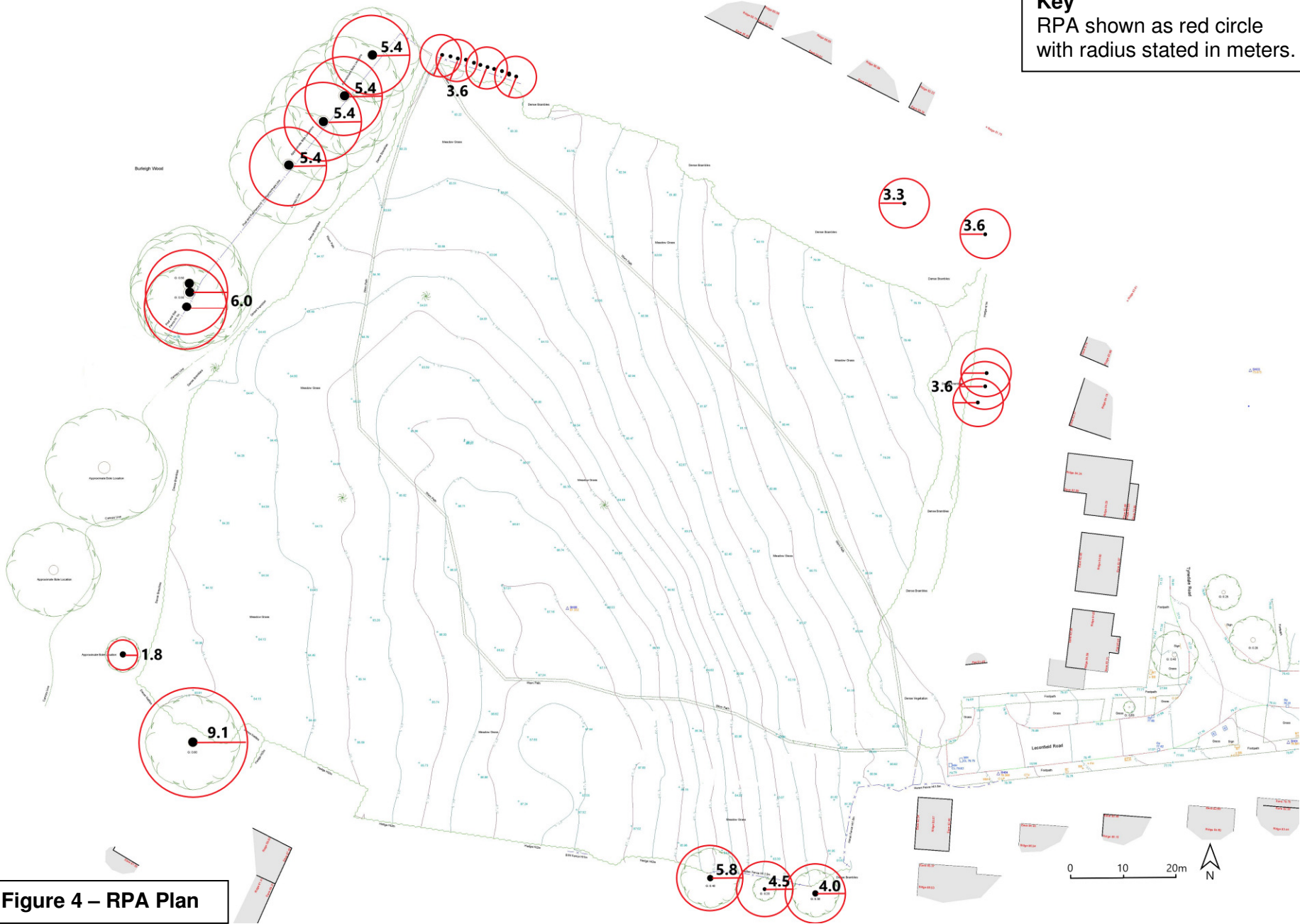

Figure 4 – RPA Plan

Figure 5 – Constraints and Tree Protection



4. Tree Management

4.1 Initial Arboricultural Assessment

In the context of this site the proposed development will comprise residential houses situated within the eastern and central areas of the field with an access from Leconfield Road. It is unlikely that any of the houses or roads will impact existing trees within the survey. The table below summarises the potential impact of the proposed development based on these assumptions and the recommendations within this tree survey on the trees present within the area surveyed.

Tree	Category	Impact of development
T1 Birch	B2	Negligible. The RPA and canopy are protected close to the field boundary and the proposed road is outside of the RPA.
T2 Birch	B2	Negligible. The RPA and canopy are protected close to the field boundary and the proposed road is outside of the RPA.
T3 Oak	A2	Negligible. The nearest structure is outside of the calculated RPA and canopy extents of this tree.
T4 Ash	B2	Negligible. The RPA and canopy extend into a landscaped area with no structures.
T5 Willow	C2	Negligible. The RPA and canopy extend into a landscaped area with no structures.
T6 Oak	A2	Negligible. The RPA and canopy extend into a landscaped area with no structures.
G7 Oak	A2	Negligible. The RPA and canopy extend into a landscaped area with no structures.
G8 Leylandii	B2	The RPA extends into a garden area but is sufficiently far from any structures to be protected effectively by fencing.
T9 Holly	C2	Negligible. The RPA and canopy extend into a landscaped area with no structures.
T10 Leylandii	B2	Negligible. The RPA and canopy extend into a landscaped area with no structures.
T11 Holly	C2	Negligible. The RPA and canopy extend into a landscaped area with no structures.

It is a reasonable assumption that the trees along the southern and eastern boundaries of the field may cast some shadow across any properties nearby during the morning and early afternoon periods. However, there are no properties near to trees T1-T3 to be impacted and Plot 21 is sufficiently far from Ash T4 to avoid impact during the morning and afternoon periods but receive shading during the middle of the day into the rear garden area. Overall, the layout proposed will provide plenty of direct sun during the early morning and late afternoon periods within any properties that have gardens near to these trees. Shading is therefore unlikely to be an issue.

Perceived risk of branch fall and leaf drop is unlikely to be an issue for any of the proposed new houses as none of the gardens will be dominated by the adjacent trees and a reasonable stand-off distance has been provided from any mature trees to mitigate against any such risk and reduce the impact of autumn leaf-drop on gardens.

4.2 General Recommendations

The trees along the eastern and northern field boundaries or within the adjacent rear garden areas will need to be adequately protected during any approved development works where the canopies or calculated root protection areas extend across the field boundary. As a general rule at this site, measures to protect trees should follow the best practice principles set out in BS5837: Trees in Relation to Design, Development and Construction (2012). Prior to any construction or development

work proceeding, the RPA's of individual trees to be retained should be marked out using the distances provided in the table within Appendix 1.

Marking out should be completed by a person with arboricultural or horticultural expertise as individual trees will have root zones that may be affected by local conditions and allowances will need to be made to accommodate this. The best practice principles have been broadly summarised below.

- All trees retained adjacent to the site should be protected by barriers or ground protection around the calculated Root Protection Area (RPA) and as indicated on any Tree Constraints Plan (TCP) that may be produced in association with the assessment.
- Any fencing required should be erected prior to commencement of construction and before demolition including erection of any temporary structures. Once set up fences should not be removed or altered without prior consultation with the arboricultural advisor.

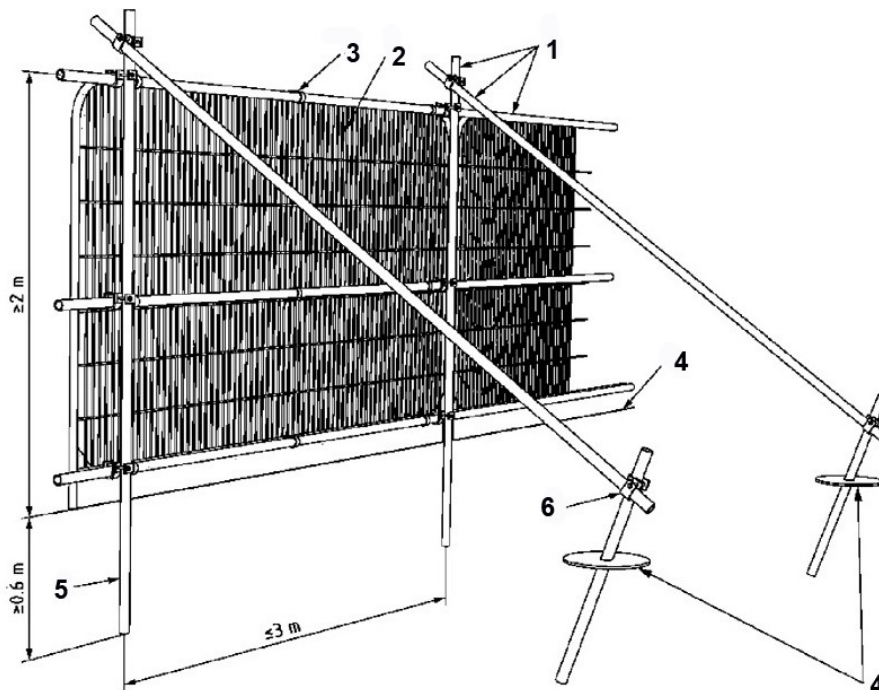

1. Standard scaffold poles
2. Heavy Gauge 2m tall galvanised tube and weld mesh infill panels
3. Panels secured to uprights and cross members with wire ties
4. Ground Level
5. Uprights driven into ground until secure (up to 0.6m)
6. Standard scaffold clamps

- Arrangements should be made for an arboriculturalist to supervise works and tree protection where trees are particularly vulnerable or sited close to access points.
- Pre-development works may be undertaken prior to the installation of fencing with the agreement of the local planning authority.
- All tree works should follow best practice procedures as set out in BS 3998 (2010). All trees should be maintained in good condition on site and be inspected annually (where overall condition requires) or every 2 years and after any major storm events, with safety a priority.
- Fencing should be clearly visible and suitable for the location, type and proximity of construction activity.

- It may be appropriate on some sites to use temporary site offices as components of the protection barriers.
- Where it has been agreed and shown on a Tree Protection Plan, construction access may take place within the RPA if suitable ground protection measures are in place (e.g. existing surfaced car park areas). In other areas this may comprise single scaffold boards over a compressible layer laid onto geo-textile materials for pedestrian movements. Vehicular movements over the RPA will require the calculation of expected loading and may require the use of proprietary protection systems.
- Once areas around trees have been protected by fencing, any works on the remaining site area may be commenced providing activities do not impinge on protected areas. Notices should be placed on fencing to indicate that operations are not permitted within the fenced area.
- Wide or tall loads etc. should not come into contact with retained trees. Banksman should supervise transit of vehicles, jibs, booms etc. where this is in close proximity to retained trees.
- Oil, bitumen, cement or other material that is potentially injurious to trees should not be stacked or discharged within 10m of a tree bole. No concrete mixing should be done within 10m of a tree. Allowance should be made for the slope of ground to prevent materials running towards the tree.
- No fires will be lit where flames are anticipated to extend to within 5m of tree foliage, branches or trunk, taking into consideration wind direction and size of fire.
- Notice boards, telephone cables or other services should not be attached to any part of a retained tree.
- Where it is deemed necessary to operate a wide or tall load, plant bearing booms, jibs and counterweights or other such equipment, as part of construction works, and such equipment would have potential to cause injurious contact with crown material i.e. low branches and limbs, of retained trees within the RPA fencing, it is best advised that appropriate, but limited tree surgery, be carried out beforehand to remove any obvious problem branches. This is classed as 'Facilitation Pruning' within BS 5837 (2012). Any such pruning should be undertaken in accordance with a specification prepared by an arboriculturalist.
- It is advised that a Pre-Commencement Site Meeting is held with contractors who are responsible for operating machinery, as described above. To firstly highlight the potential for damage occurring to tree crowns and to ensure that extra care is applied when manoeuvring machinery during such operations within close proximity to retained trees to avoid any contact.
- In the event of having caused any such branch or limb damage to retained trees it is strongly recommended that suitable tree surgery be carried out, in accordance with BS 3998 (2010) Recommendations for Tree Work, to correct the damage, upon completion of development.



Christopher Barker CEnv dipHort

Appendix 1: BS5837 Tree Schedule

Key:	Measurements	Age – Class	Overall Condition	BS 5837 2012: Cascade Chart for Quality Assessment/Retention Category	Symbols:
	MS – Multi-stemmed	YNG-MAT-Young Mature	G – Good	A – High	< = less than
	Ht - Height in metres	SM – Semi-mature	F – Fair	B – Moderate	~ = approximately
	Stem – Stem Diameter at 1.5m in mm	Mat – Mature	P – Poor	C – Low	> = greater than
	Crown – Crown spread in metres	OM – Over mature	D – Dead	U – Trees of negligible significance	
	TD - Trunk division (height in metres)	Est Yrs – estimate of years remaining (>40 years; 20 –40 years; <20 years)		Sub-categories: 1 = mainly arboricultural values 2 = mainly landscape values 3 = mainly cultural values.	

RPA = Root protection area (equivalent to a circle with a radius 12 x the stem diameter for single stem trees and 10 x the basal diameter for trees with more than one stem arising below 1.5m above ground level).

Tree No	Species	Ht (m)	Stem Diam mm@ 1.5m	Canopy Spread (m)	Height of Crown Clearance	Age Class	Est yrs	Overall Condition	Structural condition	Recommendations	BS 5837 Category	RPA Radius (m)
T1	Birch <i>Betula pendula</i>	18	340 est	5m on north side	4	M	20+	G	Single trunk situated in adjacent garden. Upright pendulous crown extends across the field boundary. Negligible roost potential. No structural faults visible from ground level	Retained. Protect the canopy and RPA on the north side with fencing. No canopy work required.	B2	4.0
T2	Birch <i>Betula pendula</i>	17	380 est	6m on north side	2	M	20+	G	Single trunk situated in adjacent garden. More broadly upright pendulous crown extends across the field boundary. Negligible roost potential. No structural faults visible from ground level	Retained. Protect the canopy and RPA on the north side with fencing. No canopy work required.	B2	4.5
T3	Oak <i>Quercus petraea</i>	15	485	6m on north side	4	M	40	G	Single trunk positioned in adjacent garden supporting a broad balanced crown of good shape extending over the field boundary. Negligible roost potential. No structural faults visible from ground level	Retained. Protect the canopy and RPA on the north side with fencing. No canopy work required.	A2	5.8
T4	Ash <i>Fraxinus excelsior</i>	18	765	8m on north side	5	M	20	F	Single trunk within an adjacent garden supporting a very broad irregular spreading canopy. Negligible roost potential. No structural faults visible from ground level	Retained. Protect the canopy and RPA on the north side with fencing. No canopy work required.	B2	9.1

Tree No	Species	Ht (m)	Stem Diam mm@ 1.5m	Canopy Spread (m)	Height of Crown Clearance	Age Class	Est yrs	Overall Condition	Structural condition	Recommendations	BS 5837 Category	RPA Radius (m)
T5	Willow <i>Salix alba</i>	8	<100	2m on east side	0	Y	10+	G	Single trunk supporting an upright lightly branching canopy situated on the woodland boundary. Negligible roost potential. No structural faults visible from ground level	Retain. Protect the RPA on the eastern side.	C2	1.8
T6	3 X Oak <i>Quercus petraea</i>	18	<500	8m on east side	0	M	40	G	Three single trunk trees situated 1m behind the boundary fence along the edge of Burleigh Wood. Crowns merge into one large canopy extending across the site boundary to ground level within the site. Low roost potential. No structural faults visible from ground level	Retain. Canopy and RPA extending across the site boundary will require protection measures.	A2	6.0
T7	5 x Oak <i>Quercus petraea</i>	16-19	<450	7m on east side	0	M	40	G	Group of Oak within the edge of Burleigh Wood. Crowns merge into one large canopy extending across the site boundary to ground level within the site. Low roost potential. No structural faults visible from ground level	Retain. Canopy and RPA extending across the site boundary will require protection measures.	A2	5.4
G8	Leylandii <i>XCupressocyparis Leylandii</i>	16	<300	2m on south side	0	M	20	F	Line of closely planted upright leylandii merging into a vertical screen. Trimmed on both side. Negligible roost potential. No structural faults visible from ground level	Retain. RPA will require protection within the field.	B2	3.6
T9	Holly <i>Ilex aquifolium</i>	6	275	2m on south side	0	SM	10	F	Single trunk supporting as fairly upright ascending canopy within an adjacent garden. Negligible roost potential. No structural faults visible from ground level	Retain. RPA will require protection within the field. No canopy work is required.	C2	3.3
T10	Leylandii <i>XCupressocyparis Leylandii</i>	10	300	2m on south side	0	SM	20+	G	Single trunk supporting an upright columnar canopy within the adjacent garden. Negligible roost potential. No structural faults visible from ground level	Retain. RPA will require protection within the field. No canopy work is required.	B2	3.6

Tree No	Species	Ht (m)	Stem Diam mm@ 1.5m	Canopy Spread (m)	Height of Crown Clearance	Age Class	Est yrs	Overall Condition	Structural condition	Recommendations	BS 5837 Category	RPA Radius (m)
T11	3 x Holly <i>Ilex aquifolium</i>	6-8	300 est	3m on west side	2	SM	10	F	Merging irregular canopy extending over the boundary from the adjacent garden. Negligible roost potential. No structural faults visible from ground level	RPA will require protection. Some trimming of the lower canopy may be required where it extends over the edge of the field.	C2	3.6